



REVIEW PAPER FOR GFDM: ADVANCEMENT AND PERFORMANCE ANALYSIS FOR 5G NETWORK

Zahraa Q. Haban^{1,2,*} and Ahmed G. Waddy³

¹ **Engineering Technical College of Al-Najaf /Al-Furat Al-Awsat Technical University (ATU).**

² **Engineer, Technical College of Management _Kufa /Al-Najaf /Al-Furat Al-Awsat Technical University, Al-Najaf, Iraq, Email: zahraa.ms.etcn31@student.atu.edu.iq.**

³ **Prof. Dr Engineering Technical College of Al-Najaf /Al-Furat Al-Awsat Technical University (ATU), Al-Najaf, Iraq E-mail: ahmadghw@atu.edu.iq.**

*** Corresponding author.**

<https://doi.org/10.30572/2018/KJE/160402>

ABSTRACT

Generalized frequency division multiplexing (GFDM) is one of the most promising candidate Multiple Access technologies for the 5G of wireless communication, as it shows great potential and benefits to help create a networked society for the next generation. GFDM is a wave technology that shows its advantages through flexibility in spectrum usage, to adapt to the requirements of channel conditions, low latency, noise reduction, as well as reduction of Out-Of-Band (OOB) emissions. In this paper, an overview of the development and performance analysis of GFDM in the next generation is presented, and a group of technologies that have been integrated and used with this technology are discussed, such as Multiple Input Multiple Output (MIMO) systems, channel coding, channel estimation, pulse shaping filters, and many other technologies. As well as other technologies that will improve the performance of wireless networks. The strengths and weaknesses of this technology will be discussed, and an analysis of the system's capabilities in terms of bit OOB, Peak-To-Average Power Ratio (PAPR), Bit Error Rate (BER), and Signal-To-Noise Ratio (SNR) will be performed. In addition to discussing researchers' visions for other technologies with GFDM and the future dimension of GFDM research.

KEYWORDS

GFDM; 5G; Prototype filter, OOB, PAPR, MIMO, Channel estimation, Channel coding.



1. INTRODUCTION

During a long journey, we have seen the evolution of wireless communication. It all started with the first generation, which allowed the transmission of voice calls. Then came the second generation, which introduced the ability to send text messages and expanded phone usage. The third generation was a real game-changer with its high-speed data transmission, enabling high-speed internet and many services. The fourth generation was an upgrade with better data transfer speed, and supporting many promising technologies in the Internet of Things (IoT) services (Kishore *et al.*, 2020)(Vaezi, Ding and Vincent Poor, 2018). The 5G takes it up a notch with features such as internet access, IoT, artificial intelligence, automation, huge increase in data capacity, and low transmission time.

Unlike previous generations, the focus will be on more than one technology. Wireless communication will create a networked society (Liu and Ap, no date). Some of the services allocated to the 5G network include low latency and Ultra-Reliable Communications (URLLC), as reliability is now a key focus. To provide internet access to areas with low population density and address many problems, a natural flexible material is required (Matthé *et al.*, 2016). To manage the challenges, scenarios, and requirements of 4G, Orthogonal frequency division multiplexing (OFDM) was used, which is considered the essence of 4G technology.

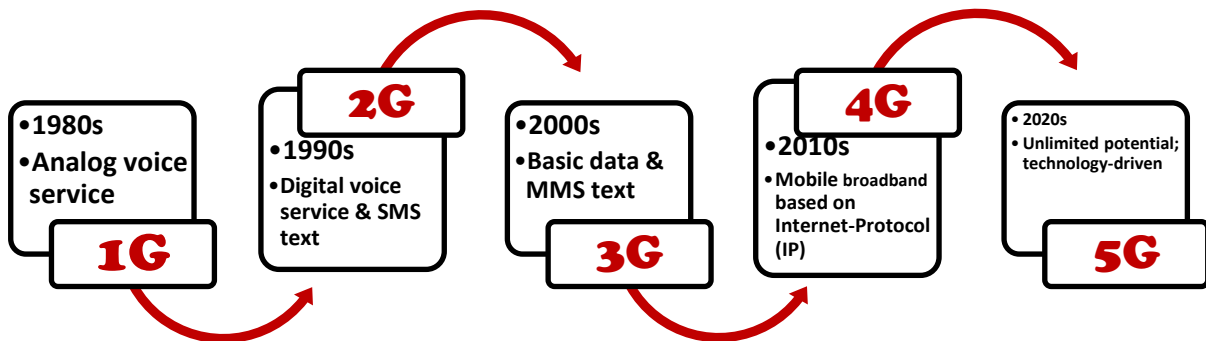

Fig.1. Evolution of Network.(Kishore *et al.*, 2020)

The requirements of 5G wireless networks are not adequately met by OFDM due to its rectangular pulse shape leading to high OOB emissions and sensitivity to synchronization errors.

Moreover, the inclusion of a periodic prefix in each symbol hampers low access time and reduces spectral efficiency. To address these issues, several waveform filters have been proposed for the material layer, including Non-Orthogonal Multiple Access (NOMA), GFDM (Generalized Frequency Division Multiplexing), Universal Filtered Multi-Carrier (UFMC), and Filter Bank Multi-Carrier (FBMC) in 5G wireless networks (Öztürk, Basar and Çirpan, 2017). GFDM is a technology that is being researched and developed as a promising candidate for 5G.

It offers greater spectral efficiency compared to OFDM and can reduce power loss without the need to maintain orthogonality (Nimr *et al.*, 2017)(Yadav, 2022). Ameer *et al.* conducted an in-depth performance-based comparison between GFDM and OFDM. The study revealed the effects of pulse shaping, which in this case reduces the BER performance of GFDM while it outperforms in terms of SNR, OOB, and Power Spectral Density (PSD) of the signal (Ali and Hreshee, 2022). It has a large capacity, fast response time, and high speed to the extent even up to 10 GB/s (Kishore *et al.*, 2020).

The subcarriers are filtered with pulsed responses in the GFDM filter. The GFDM waveform has a flexible shape and is appropriate for the transmission of block signals because it establishes two-dimensional data mass in the frequency and time domains (Nimr *et al.*, 2017). GFDM addresses the need for careful design of the prototype filter together with the structure of the transmitter and receiver (Tai, Wang and Huang, 2020). This is to minimize or mitigate the effects of interference-Inter-Symbol Interference (ISI) and Inter-Carrier Interference (ICI). ISI comes about because symbols that are transmitted through a channel are overlapping and hence cause signal distortion and errors in the received signal (Tai, Wang and Huang, 2020). Researchers have not yet stopped in the quest for waveforms that have high spectral efficiency at multi-wavelength such that it offers a higher quality of service, higher data rates with lower OOB, lower access due to the different requirements of 5G technology (Kishore *et al.*, 2020). GFDM is basically the development of multi-carrier modulation techniques in communications systems as a probable technology for 5G networks which gives improved spectral efficiency as well as flexibility and robustness compared to OFDM (Gaspar *et al.*, 2015). Therefore, GFDM shall be applied in different 5G use cases, where applicable include Massive Mached Communications, Enhanced Mobile Broadband, and Ultra Reliable Low Latency Communications.

- In mMTC, for example, GFDM allows communication of many devices with very low energy and low data rate consumption. One main application is IoT such as smart cities, industrial automation, and smart homes where many devices need to connect. The ability of GFDM to support a very large number of users and devices makes it a very attractive solution to mMTC.
- Enhanced Mobile Broadband (eMBB): GFDM can be applied to eMBB, for which low latency and high data rates are necessary. 4K video streaming, online gaming, and virtual reality are some applications that require high-quality user experience. GFDM supports those requirements and is therefore suitable for eMBB applications as well because it can deliver high spectral efficiency along with flexibility in operation (Andrews *et al.*, 2014).

- **Ultra-Reliable Low Latency Connections:** In the requirement of URLLC for extremely low latency and high reliability, which is most desirable for applications such as autonomous vehicles, smart grids, and telehealth, where trustworthy and timely communication is indispensable, GFDM is workable. In the above applications URLLC is critical. GFDM can work URLLC, as it can guarantee extremely low latency yet reliable communication (Park et al., 2022).

It can support different 5G use cases, for example, mMTC, eMBB as well as URLLC, and its spectral efficiency, flexibility, and robustness advantages further enhance its proposition as a very attractive 5G network approach. It will discuss in the second part the transmitter and receiver of the GFDM system, and in the third, the GFDM waveform and its mathematical model. The fourth section has carried out the performance of GFDM compared with the rest of the promising 5G technologies. The fifth section reviews references that are well applied and summarizes the proposals and conclusions that are presented by the researcher.

The classification presented in this paper is by the technique of measuring GFDM performance. Conclusions of the paper are in Section VI.

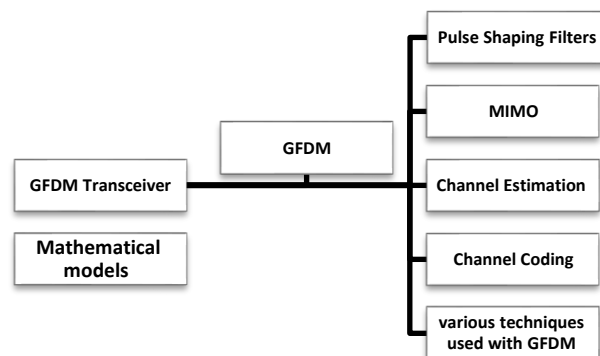

Fig. 2. A Review of GFDM; the organization of the main themes in this paper.

2. GFDM TRANSCIEVER

The GFDM transceiver is a multi-carrier modulation system that uses a set of filters to divide the available bandwidth into several smaller sub-bands, which are then modulated using a set of modulation systems such as PSK, QAM. The GFDM transmitter and receiver consists of (Ali and Hreshee, 2022):

- **GFDM transmitter:** The transmitter is responsible for modifying the input data on the subcarriers and sending the signal through the channel. The device consists of:

Data Source: Creates the input data to be sent, and then the data is reshaped to an $N \times M$ matrix size.

Modulator: It maps the subcarriers using a modulation scheme such as QAM or PSK.

Filter bank: A set of filters that divide the bandwidth into subcarriers. Each filter has a

frequency response to modulate the subcarriers.

Adding a cyclic prefix: A cyclic prefix is added to mitigate the effects of multipath fading.

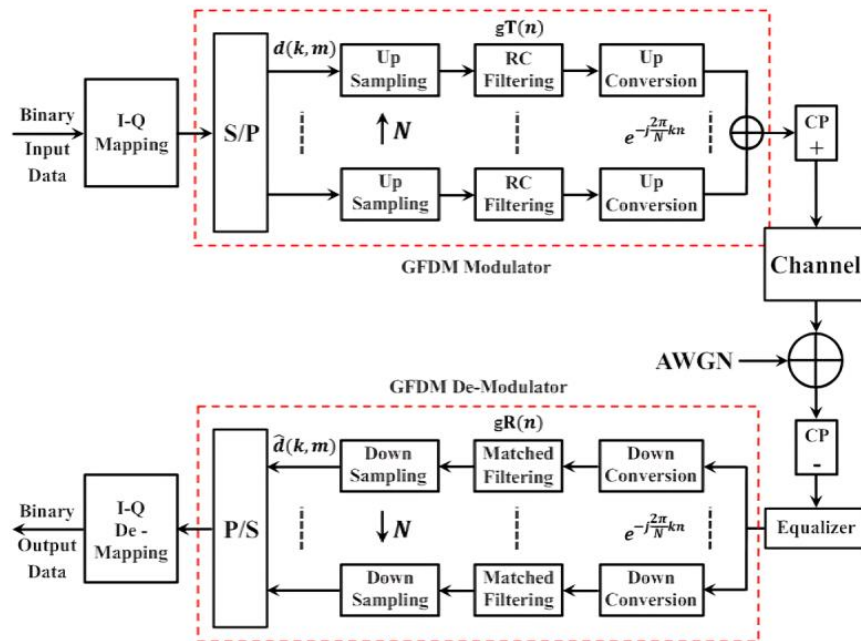

Fig. 3. GFDM- Transceiver (Maraş *et al.*, 2021).

- **Channel :** The AWGN channel adds noise to the transmitted signal.
- **GFDM receiver:** The receiver is responsible for demodulating the signal and restoring the original data, as it consists of:

Remove the cyclic prefix from the received signal By M , the FFT is shifted to deallocate subcarriers from the filters in the bank.

Demodulator: It demodulates the subcarriers using the inverse modulation scheme the transmitter uses.

- Several techniques are used to reduce the complexity of the transmitter and receiver, such as the Fast Fourier Transform (FFT) and the Fast Convolution (FC) algorithm (Li *et al.*, 2019) to efficiently calculate the convolution of the signal in the form of a pulse with the impulse response of the channel.
- The receiver structure can be designed to support multiple receiving techniques such as MF, zero forcing, and minimum mean square error (MMSE) receivers.

3. MATHEMATICAL MODELS OF GFDM

The GFDM matrix is the most suitable representation of the modulation and demodulation matrices, which follow the same structure. In the GFDM system, every block is sent and represented by KM . Here, K represents the number of sub-carriers and M represents the number of sub-symbols (Tai, Wang and Huang, 2020).

3.1. Modulation Matrix Mode

Assuming a vector $\mathbf{x} \in \mathbb{C}^{N \times 1}$ represents one block of GFDM, which is based on multi-band communication (Kalsotra et al., 2019). The pulse shape can be represented by the $[\mathbf{g}_{k,m}]_n$ factor, which is calculated using the following formula (Vaezi, Ding and Vincent Poor, 2018).

$$[\mathbf{g}_{k,m}]_n = [\mathbf{g}]_{\langle n-mK \rangle_D} e^{\frac{j2\pi kn}{K}}, n = 0, 1, \dots, D-1, m = 0, 1, \dots, M-1, k = 0, 1, \dots, K-1$$

(Vaezi, Ding and Vincent Poor, 2018; Kishore et al., 2020) (1)

$[\mathbf{g}_{k,m}]_n$: The pulse shape factor, It can be calculated by the formula above.

$g[n]$: The prototype filter.

K : The sub-carrier index, ranging from 0 to $K-1$.

M : The subsymbol index, ranging from 0 to $M-1$.

n : The time index, ranging from 0 to D , where D is the length of the GFDM block.

When using the GFDM, a block of transmitted bits is applied to an input. The output produces a vector D that can be broken down into K subcarriers, each containing M sub symbols.

$$D = [d_0^T, d_1^T, \dots, d_{K-1}^T]^T \quad (2)$$

The duration of each symbol vector \mathbf{d}_k is MT_s , where T_s is the symbol interval on each subcarrier. The subcarrier gap is equal to $1/(MT_s)$. M is a subvector of the k th subcarrier represented by the vector (Kalsotra et al., 2019).

$$[\mathbf{x}]_{(n)} = \sum_{m \in \mathcal{M}_{on}} \sum_{k \in \mathcal{K}_{on}} d_{k,m} g[\langle n - mK \rangle_N] e^{j2\pi \frac{k}{K} n} \quad (\text{Vaezi, Ding and Vincent Poor, 2018})(\text{Nivetha and Sudha, 2021}) \quad (3)$$

\mathbf{x} : The n^{th} sample of the GFDM block \mathbf{x} .

$\langle \rangle$: The triangular brackets " $\langle \rangle$ " represent the modulo operator.

We can represent the above equation in the frequency domain:

$$[\tilde{\mathbf{x}}]_{(n)} = \sum_{m \in \mathcal{M}_{on}} \sum_{k \in \mathcal{K}_{on}} d_{k,m} \tilde{g}[\langle n - kM \rangle_N] e^{-j2\pi \frac{m}{M} n} \quad (\text{Vaezi, Ding and Vincent Poor, 2018})$$

$d_{k,m}$: The data symbol on the K^{th} subcarrier and M^{th} subsymbol.

\mathcal{K}_{on} : The set of active subcarrier.

\mathcal{M}_{on} : The set of active subsymbol.

The last L_{cp} is copied to add the CP "cycle prefix" to the beginning and the L_{cs} CS "Cyclic suffix" to the end of \mathbf{x} .

Thereby;

$$[\mathbf{x}]_{(n)} = \sum_{k=0}^{K-1} [\mathbf{A}]_{(n,k+mK)} [\mathbf{d}]_{(k+mK)} \quad (\text{Nivetha and Sudha, 2021}) \quad (4)$$

A: The modulation matrix, element at the n^{th} row and $(k + mK)$ the column.

After passing through the pulse-shaping filter, the sequence is transmitted through an ideal Additive White Gaussian Noise.

3.2. Demodulation Matrix Model

The equal received signal represented by $y[n]$, denoted by the vector $y \in \mathbb{C}^{N \times 1}$, is demodulated using a typical receive filter $\gamma[n]$. Estimated data symbols are expressed as (Vaezi, Ding and Vincent Poor, 2018):

$$[\hat{d}]_{(k+mK)} = \sum_{n=0}^{N-1} y[n] \gamma^*[\langle n - mK \rangle_N] e^{-j2\pi \frac{k}{K} n} \quad (5)$$

After receiving the signal, various linear receiver schemes are considered for demodulation. The data matrix is then written after linear processing (Vaezi, Ding and Vincent Poor, 2018).

$$\hat{d} = B^H y \quad (6)$$

\hat{d} : the vector of estimated data symbols.

$B^H y$: the Hermitian transpose of the demodulation matrix B .

$$[B^H]_{(k+mK,n)} = \gamma^*[\langle n - mK \rangle_N] e^{j2\pi \frac{k}{K} n} \quad (7)$$

$$[B]_{(n,k+mK)} = \gamma[\langle n - mK \rangle_N] e^{j2\pi \frac{k}{K} n} \quad (8)$$

$\gamma[n]$: is the receive filter used in the demodulation process of the GFDM signal.

γ^* : The complex conjugate of the receive filter $\gamma[n]$.

$\gamma^*[\langle n - mK \rangle_N]$: The complex conjugate of the receive filter at the n^{th} sample.

The GFDM block varies depending on the targeted applications for GFDM services, after estimating the modulation process parameter ' \hat{d} ' (Vaezi, Ding and Vincent Poor, 2018; Tai, Wang and Huang, 2020).

3.3. cyclic prefix

The cyclic prefix is a signal introduced in GFDM to mitigate inter-symbol interference, which can occur due to the lack of orthogonality between the subcarriers in general [8]. Adding the cyclic prefix to GFDM achieves better robustness against channel weakness and a higher data rate in frequency-selective fading channels, although it comes at the expense of losses in spectrum efficiency (Chuang, Ueng and Shen, 2021). This improvement in overall performance helps to avoid inter-symbol interference.



Fig. 4. Cyclic prefix addition (Kumar et al., 2018).

- A periodic prefix is added to the transmitted signal, and its purpose in OFDM is to provide a guard interval between symbols to perform synchronization and channel estimation. While in GFDM, it helps reduce interference between subcodes within the block (Ali and Hreshee,

2022).

- The length of the CP varies, as it is a fixed part in OFDM. While in GFDM the CP length can be adjusted to suit the system requirements and channel conditions (Tai, Wang and Huang, 2020).

4. COMPARATIVE OF GFDM, OFDM, NOMA AND F-OFDM

5G requires designing a waveform that meets the increasing requirements for high data rates and improved spectral efficiency in addition to low latency. OFDM, GFDM, F-OFDM and NOMA are among the most promising waveform candidates that have been proposed to meet the challenges of 5G.

4.1. GFDM, OFDM

Both GFDM and OFDM are subcarrier modulation schemes, but they differ in the allocation and filtering of subcarriers.

- GFDM allows flexible assignment of subcarriers providing adaptation to channel conditions while OFDM uses fixed subcarrier spacing (Michailow et al., 2014).
- The PAPR ratio appears lower in GFDM compared to OFDM to reduce the nonlinearity of the power amplifier (Sameen et al., 2017).

4.2. GFDM, NOMA

Both NOMA and GFDM are designed to improve spectral efficiency, GFDM uses a multi-carrier approach while NOMA uses non-orthogonal waves where multiple users share the same time frequency resources (Islam et al., 2019).

- GFDM relies on filtering to manage cascade interference, while NOMA uses successive interference cancellation(SIC) to manage interference (Islam et al., 2019).
- GFDM has less complexity compared to NOMA due to the need for SIC.

4.3. GFDM, F-OFDM

Both of these techniques are multi-carrier modulation schemes and filtered carriers, but the difference is in the filters and sub-carriers designs.

- GFDM uses a Gaussian filter while F-OFDM uses a rectangular filter with an elastic decay factor (Amerttet, 2022).
- FOFDM achieves higher spectral efficiency than GFDM due to the elastic roll of factor.

5. LITERATURE REVIEW

In 2009, Vodafone and Gerhard Fettweis along with his research team were the first ones to demonstrate GFDM technology. Their research on GFDM technology continued at the

technical university of Dresden in Germany. The proposed approach has a number of advantages, amongst which are lower PAPR and reduced OOB radiation. It could also be used effectively as an option for the aggregation of whitespace. Gerhard Fettweis has inspired numerous researchers to continue his approach and to work on the development of this technology including its incorporation into 5G standards, performance measurements, comparison of alternative systems, and integration with others. The subsequent section reviews, briefly, some of these research centers ([Fettweis, Krondorf and Bittner, 2009](#)).

Table 1. Comparative of GFDM, OFDM, NOMA and F-OFDM.

Technology	Peak-to-Average Power Ratio (PAPR)	Bit Error Rate (BER)	Out-of-Band (OOB) Emissions	Multiple Access Capability	Complexity	Performance
GFDM(ERSİN ÖZTÜRK and ERTUGRUL BASAR, 2017)	Flexible and adaptable	Better than OFDM	Reduced	Non-orthogonal	High	Robust against channel impairments
OFDM	High	Higher than F-OFDM	High	Orthogonal	Low	High spectral efficiency, widely used in wireless systems
NOMA(Al-Dulaimi et al., 2023)	Higher than OFDM	Better than OFDM	High	Non-orthogonal	High	Better spectral efficiency and user fairness
F-FDM (Amertet, 2022)	Lower than OFDM	Better than OFDM	Suppressed	Orthogonal	Low	High spectral efficiency, but sensitive to channel impairments

5.1. Pulse Shaping Filters in GFDM

Pulse shaping filters, in their role of influence on the system, have been identified to not only critically affect BER but also reduce inter-symbol interference between ISI symbols and minimize OOB radiation of the transmitted signal ([Nivetha and Sudha, 2021](#)). Perfect usage of the filter, in return, would uplift the spectral characteristics of the GFDM system, therefore improving its efficiency and performance ([Sim et al., 2020](#)). This relates strongly to 5G network precedence, with modulation filters already identified as one of the promising technologies used in numerous wireless communication applications ([Sim, 2020](#)). Different pulse modulations' performance concerning the system has been researched by numerous scholars and some of their identified relationships are shown below:

V. Nivetha et.al (Nivetha and Sudha, 2021); The Paper analyzes and compares various pulse shaping filters to determine their impact on BER. Improved Sinc Power (ISP) and high cosine or BTRC are considered. Others are Parametric Exponential (PEXP) and Parametric Linear Pulse (PLP).

Surbhi et.al (Kalsotra et al., 2019) The paper focuses on optimizing Nyquist pulse shaping filters for GFDM and evaluating the performance of OOB and symbol error probability(SEP) through Monte Carlo simulation. Zee Ang Sim (Sim, 2020) The thesis focuses on reducing PAPR in multi-carrier communication systems, specifically in GFDM and OFDM, to enhance system performance.

ZEE et.al (Sim et al., 2020) The paper discusses the use and comparison of Quadrature Programming (QP) pulse shaping filters to reduce (OOB) radiation compared to a Raised Cosine (RC) filter in GFDM system.

Megha et.al (Gupta and Gamad, 2023) The paper discusses how filters, like RC and Root-Raised Cosine (RRC), affect the analysis of Symbol-Error-Rate (SER) and Single-to-noise ratio (SNR) in the presence of AWGN.

Table 2. The Pulse Shaping Filters in GFDM: A Review of Previous Studies.

Pulse shaping filter type	Performance	Channel and reception
Parametric Exponential (PEXP) (Nivetha and Sudha, 2021)	High SNR has better performance than RC	MMSE receiver, AWGN channel
Parametric Linear Pulse (PLP) (Nivetha and Sudha, 2021)	High SNR has better performance than RC	MMSE receiver, AWGN channel
Improved Sinc Power (ISP) (Nivetha and Sudha, 2021)	Better performance in terms of BER compared to other types	MMSE receiver, AWGN channel
Better Than Raised Cosine (BTRC) (Nivetha and Sudha, 2021)	High SNR has better performance than RC	MMSE receiver, AWGN channel
Universal Filtered Multi-Carrier(UFMC)(Zhang et al., 2017)	Better BER, reduces complexity	Rayleigh block fading channel Rayleigh channel,
Root-Raised Cosine (RRC) (Gupta and Gamad, 2023)	improve SER	AWGN channel, Zero-forcing receiver channel

5.1.1. The main topics of the studies presented:

- An important advantage of GFDM is the low PAPR compared to OFDM.
- Improving BER performance by combining SC techniques diversity reducing both BER and OOB by improving the pulse shape and using several types of filters to expand the study of the technique.

- Most studies focused on the performance of PAPR, OOB, and BER emissions, but did not mention the response time and signal-to-noise ratio.
- Several types of pulse shaping filter were discussed in (Kumar *et al.*, 2018) and their performance in terms of BER was compared to the MMSE receiver via the AWGN channel, but the ratio of OOB, ISI, and ICI was not highlighted, in contrast to (Nivetha and Sudha, 2021) which compared two types of pulse shaping filter and the comparison of the performance with the several of receivers.
- The proposal to measure the performance of (Kumar *et al.*, 2018) types of filters with several types of receivers under different channel conditions, to study new methods, and estimate their suitability for a GFDM system.

5.2. MIMO Techniques In GFDM

GFDM is a technique that preserves most of the beneficial properties of OFDM while addressing most of its limitations. Hence, researchers have started using the most promising technologies in communication systems and measuring their performance with GFDM. One of these technologies is Multiple-Input Multiple-Output (MIMO), which, when combined with GFDM, produces a MIMO-GFDM system. This system uses multiple antennas in both the transmission and reception parts, allowing for the synchronization of multiple data in the transmission. The signals received from all antennas are processed to extract the transmitted symbols. This combination of MIMO-GFDM provides spatial diversity, improving the system's robustness against interference and fading, increasing the data flow rate, and achieving high efficiency due to GFDM's waveform flexibility compared to OFDM (Kusumakar, Pancholi and Tiwari, 2019).

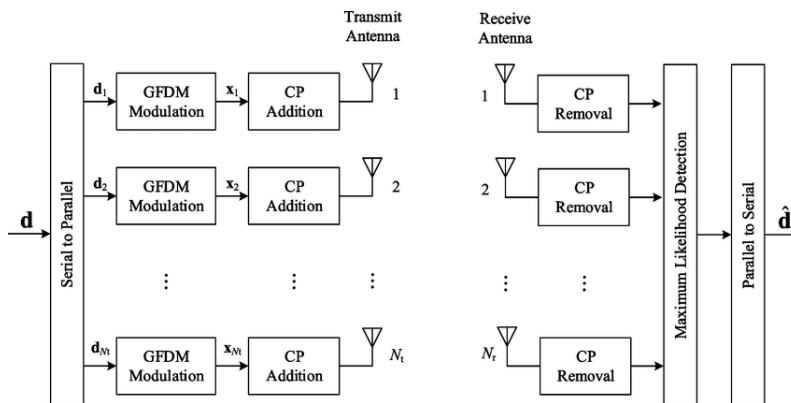

Fig.5. MIMO-GFDM.

TABLE 2. A comparative analysis of various MIMO-GFDM technologies discussed for 5G parameters

Authors	Objective	Evaluated Parameters
Shahab et.al (Ehsanfar <i>et al.</i> , 2019)	Calculating interference statistics in GFDM waveform using the MIMO_	Channel estimation performance,

Authors	Objective	Evaluated Parameters
	Linear Minimum Mean Square Error (LMMSE) method. Comparison with OFDM for CP-assisted LMMSE-Parallel Interference Cancellation (PIC) channel estimation.	equalization performance, frame error rate.
JIE ZHONG, et.al (Zhong <i>et al.</i> , 2018)	To improve the accuracy of GFDM_MIMO system, a Frequency Domain Equalization (FDE) algorithm is proposed. Furthermore, to achieve high data transfer rates, Spatial Division Multiplexing (SDM) systems are discussed.	higher transmission rates, system capacity, reliability, latency, and reduce OOB remains.
Ari Endang et.al (Jayati <i>et al.</i> , 2018)	To address distortions and ensure effective and reliable signal transmission, the research focuses on the effects of nonlinear distortion High Power Amplifier (HPA) in MIMO-GFDM systems.	BER, power amplifier characteristics,
Ersin Öztürk , et.al (Öztürk, Basar and Çırpan, 2019)	Proposing an efficient wireless transmission system based on Sparse Multicarrier _Generalized Frequency Division Multiplexing _Index Modulation (SMX-GFDM-IM) to enhance spectral efficiency beyond 5G.	OOB emission, bit error rate, computational complexity, and spectral efficiency.
Ching-Lun Tai , et.al (Tai, Su and Jia, 2019)	Study of typical GFDM filters and exploitation of Frequency Domain Decoupling (FD) to reveal the First Deep Field Decoding (DFSD) for MIMO-GFDM spatial multiplexing.	The use of Dirichlet filters, reduction in complexity, and symbol-error-rate (SER) improvement.
J. Kassam , et.al (Kassam <i>et al.</i> , 2020)	Developing a hybrid equalizer for mm Wave massive MIMO GFDM systems to achieve high performance while reducing complexity	out-of-band emissions, a reduction in (PAPR), and mm Wave massive MIMO systems
Feng-Cheng Tsai ,et.al (Tsai, Ueng and Lin, 2021)	The combination of GFDM, MIMO, TR, and ZF massive equalization is aimed at improving the performance of future communication systems and increasing high data transfer rates.	improve the signal-to-noise ratio (SNR). Receiver complexity, computational efficiency, bit error rate,
Mohammed Jabbar et.al (Ameen and Hreshee, 2022)	The proposed system uses GFDM, Pulse Shaping Modulation (PSM), and massive MIMO to encrypt audio with MMSE pre-encryption technology.	Physical layer security

5.3. Channel Estimation Techniques in GFDM

Accurate reception and decoding of the transmitted signal in communication systems requires channel estimation, which includes estimation of the channel's impulse response (Shayanfar,

[Saeedi-Sourck and Farhang, 2018](#)). This section explores various techniques and new methods for estimating channels in GFDM systems. The authors cover both basic and advanced algorithms for GFDM technology, including a presentation of some of the research in this field: ZHENYUNA et.al ([Na et al., 2018](#)) In this paper, a proposed receiver addresses the crucial channel estimation problem for spectrum sensing in cognitive radio networks. Jinkyong Jeong, et.al ([Jeong et al., 2018](#)) proposed a system to eliminate interference in GFDM by using eigendecomposition pre-and post-processing. Al Kautsar et.al ([Permana and Hamid, 2018](#)) have narrated their work aimed at reducing the Mean Square Error as well as increasing the channel estimation accuracy through DFT channel estimation for GFDM.

Shahab et.al ([Ehsanfar, Chafii and Fettweis, 2019](#)) enrich channel evaluation execution by leveraging the GFDM queue design, counting utilizing CP data and extricating Wiener-Hopf channels for channel assessment. Recreation comes about with an apparent error rate of up to 1.45 dB compared to the OFDM framework. Mohanraj et.al ([Mohanraj and Dananjayan, 2020](#)) This paper proposes a strategy to cancel impedance in recipients through an iterative prepare and make strides channel exactness through Pressure sensing focuses on the effects of ICI and ISI. Ameer et.al ([Ameer H. Ali and Hreshee, 2023](#)) proposed a new method for channel estimation using Artificial Neural Networks (ANN) and compared it with LS and NLMS. The proposed method shows promising results for reducing the degradation caused by frequency-selective multipath fading channels.

5.3.2. The main topics of the studies presented:

- Researchers have used several methods, including DFT and different techniques, to meet the challenges of channel estimation in GFDM, and the use of cyclic prefixes.
- Further, proposing techniques to improve the accuracy of channel estimation in GFDM, including techniques such as Artificial Neural Networks, and reducing the effects of ISI and ICI in GFDM systems.
- The method proposed by ([Ameer H. Ali and Hreshee, 2023](#)) to estimate the channel and compare it with other methods is a variation of the techniques used with GFDM. We ANN is proposed with different channels to study its analysis, taking into account response time calculation and system complexity.

5.4. Channel Coding with GFDM

In this section of reference review, some papers are studied which discuss advanced types of channel coding and their impact on GFDM system for 5G. In 2018, Hosin et.al ([Merah, Mesri and Tahkoubit, 2018](#)) has proposed a GFDM channel coding system for 5G and combined the

advantages of combining Turbo code and LDPC code to minimize the error rate as well as enhancing the system performance. In 2019, YAN LI, et.al; (Li, Niu and Dong, 2019) evaluated the performance, complexity, and improvement of PC-GFDM compared to polar coded and GFDM. In 2019, Ann Carolyn et al; (Rajappa et al., 2020) they proposed to combine golden code with GFDM to evaluate the system performance by BER and measure the signal-to-noise ratio. In 2021, Yanpeng et.al; (Wang and Fortier, 2022) comprehensively analyzed LDPC-coded GFDM systems and measured BER and error correction in GFDM systems via Rayleigh and AWGN channels. In 2023, Ameer et.al; (Ameer H Ali and Hreshee, 2023) researchers proposed a method to improve BER in the presence of multipath fading channels and AWGN by enhancing GFDM systems using polar code while applying several types of interleaving, including (spiral, random, matrix). In 2023, R. Hema et.al; (Hema, Ananthi and Diana, 2023) utilized the GFDM technique to enhance the performance of underwater wireless optical communication systems. They achieved this by reducing OOB emissions and improving data rates using various types of coding such as BCH and RS. The team's efforts were aimed at reducing interference between codes and improving the overall efficiency of the system. The types of channel coding used by the above researchers with GFDM technology are summarized as follows: Reed- Solomon (RS), Polar Code (PC), Low-Density Parity Check (LDPC), Golden Code, Bose Chaudhuri Hocquenghem (BCH).

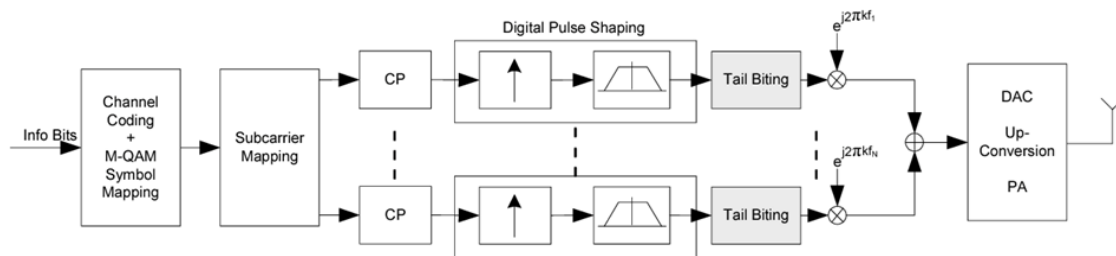

Fig. 1. Block diagram of the GFDM transmitter with channel coding (Fettweis, Krondorf and Bittner, 2009).

5.4.1. The main topics of the studies presented:

- The researchers employed various channel models to enhance the functioning of the GFDM systems. coding techniques, which include Turbo code, LDPC, Polar code, Golden code, and BCH. minimize the percent error and combat the results of multipath fading and AWGN.
- The application of GFDM makes the other communication systems more efficient, e.g., Mitigating OOB emissions with economic improvement of data: underwater optical communications transfer rates.

- We suggest using other types of channel coding such as Reed–Muller codes, Multidimensional parity-check codes, Toric codes, etc. and the extent of their impact on the GFDM system and focusing on reducing the OOB, PAPR ratio and calculating the system complexity.

5.5. Different techniques and methods with GFDM

Keiichi et.al ([Mizutani et al., 2018](#)); In this paper, a new technique called Universal Time-Frame GFDM (UTW-GFDM) is proposed for long-Term Evaluation (LTE) to improve the OOB drop of uplink systems. This technique provides an evaluation of the performance of Block Error Rate (BLER) and PAPR characteristics by using the Extended Typical Urban Channel (ETU) model. To evaluate the performance that was previously determined by 3GPP. Simulation results have brought forward a reduction in PAPR and BLER with major reductions in OOB, thus making it a probable candidate for usage of LTE in uplink systems besides future wireless communication applications. Also, UTW-GFDM was compared to GFDM for mapping types (64 QAM, QPSK).

Dick et.al ([Carrillo et al., 2018](#)); In this paper, the minimum mean square error (MMSE) on the selective fading channels of the GFDM system was considered. A new method for calculating the bit error rate of an M-QAM modulation system was presented in this paper, together with an approximate PDF of SINR that they derived. To develop into an effective tool for providing BER calculation in a GFDM system, using an MF filter on the receiving side of GFDM will result in self-interference, and to mitigate, Researchers suggest tackling this problem by using both Zero Forcing (ZF) and MMSE techniques.

Byungju et.al ([Lim and Ko, 2018](#)); suggested the best filter guidance on reception of GFDM in uplink MUI transmission. The filter diminishes the impacts of Carrier Frequency Shift (CFO) that creates interference between the multi-user (TO) and time shift, and elevates the Signal-to-Interference Ratio (SIR) of the wanted interface. The results of simulation prove that the proposed filter enhances performances of the systems based on the GFDM without compromising the spectral performance against the Guard Subcarrier (GS-GFDM). Its ability to lessen Multi User Interference (MUI) that are a result of TO and CFO is as well determined.

Mohanraj et.al ([Mohanraj and Dananjayan, 2019](#)): The study focuses on analyzing the performance of the GFDM system that employs variable window LDGT. The researchers proposed a prototype filtering technique that enhances the BER performance of GFDM systems and reduces interference, making it a promising candidate for future 5G wireless applications. Simulation results indicate that the BER results of the Localized Discrete Gabor Transform

(LDGT) are superior to various technologies used in GFDM receivers. However, larger window sizes lead to better BER performance while increasing implementation complexities in GFDM systems.

Zhongju et.al ([Li, Nimr and Fettweis, 2019](#)) The paper presents a proposed FPGA implementation of a GFDM modem with radix-2 parameters. The proposed implementation of radix-2 is based on the DFT-based architecture GFDM. The implementation allows runtime reconfiguration and supports time and frequency domains. Hardware utilization, latency, and Mean Square Error (NMSE) are evaluated. The application has a pipelined architecture and runs at a clock frequency of 250 MHz at Universal Software Radio Peripheral (USRP) which reduces hardware resource consumption, achieves high throughput, and maintains low latency. NMSE is negligible for the 256-QAM modulation. The paper provides a detailed overview of the GFDM framework, FPGA implementation details, and performance metrics.

Khalil et.al ([Aissaoui, Mhatli and Attia, 2019](#)) The paper focuses on evaluating the performance of a high-bit-rate CO-MB-GFDM signal over a long-range nonlinear Standard Single-Mode Fiber (SSMF) link. The received signals are processed through digital signal processing of the proposed system, in addition to evaluating the system performance by both BER and error vector magnitude (EVM). To meet the requirements of the 5G generation, researchers have contributed to the understanding of multi-band frequency division multiplexing (MB-GFDM) and its application in long-range fiber communication systems. The frequency bands are transmitted through a Quadrature Mach-Zehnder Modulator (IQ-MZM).

Wheberth et.al ([Dias, Mendes and Rodrigues, 2019](#)) for using an innovative equation to solve the costliness problem that arises from the receiver. The receiver complexity in GFDM at the frequency domain involves complexity from MMSE and ZF receivers. This shows the general performance of the designed equalizer for SISO or multiple-in, multiple-out (MIMO) under frequency-selective fading channels, all this with an evaluation through the paper which discusses the complexity of the receiver fully exploiting the characteristics of the GFDM waveform, analyzing the Symbol Error Rate (SER) performance of the receiver over frequency-selective fading channels.

ZHENYU et.al ([Na et al., 2019](#)) This paper establishes a GFDM based cooperated relay system with a WPC scheme. The system aims to ensure that the destination node receives the maximum data rate while at the same time providing a minimum residual energy for cell-edge users in the 5G mobile communication system. GFDM based WPC systems were proved to be superior to the classical OFDM in terms of resulting efficiency. The aim of this study is to achieve higher

quality of experience and enhanced battery lifespan through the power transferred across sub-blocks to the cell-edge.

M.Kaviya et.al ([Kaviya and Sumathi, 2020](#)) This deals with the studies on the nature of nonlinear distortion in an MIMO-GFDM system passing through an HPA at high power. To determine compensation for the nonlinear distortion effects, the HPA, Matched Filter and Zero Forcing are combined; the study takes the effect of HPA amplitude distortion on spectrum, PAPR and BER under an AWGN channel. The results of the simulation show that the HPA system had better range parameters with lower BER values and increased PAPR because of the memory-induced nonlinearity of the HPA at the saturation region .

Siva et.al ([Valluri, Vejandla and Mani, 2020](#)) This paper investigates the advantages of GFDM over OFDM and proposes a low-complexity implementation method for a GFDM receiver using a Universal Software Radio Peripheral (USRP). This method reduces computational complexity of the receiver by exploiting the circular block nature of the GFDM modulation matrix. Validation of the method was made through simulations and implementation on USRP hardware and Lab VIEW software, with the proposed approach managing to reduce computational complexity without compromising BER performance.

Amirhossein et.al ([Mohammadian and Tellambura, 2020](#)) In this paper, it is demonstrated that two-way transceivers such as GFDM can manage the attenuation along with nonlinear Power Amplifier (PA) effects within the cross-spectrum slot link. Cognitive as well as full-duplex radios will help solve this crisis while giving a significant push for developments with emerging wireless standards beyond 5G. The paper includes digital and analog SI cancellation techniques under the scenarios of two independent oscillators and a common oscillator for each transmitter and receiver.

M. Qurratulain et.al ([Khan and Danish Nisar, 2021](#)) The paper explores the use of standard orthogonal space-time block codes (OSTBC) to achieve multi-antenna transmission diversity in GFDM, which can improve robustness in multipath wireless channels with multi-antenna transmission and reception diversity. The researchers propose a framework that combines standard orthogonal space-time block codes with time-reversal coding and simple linear receivers to achieve multi-antenna transmission diversity in GFDM. The paper demonstrates that the full diversity arrangement of the four and eight transmitting antennas can be achieved, and increasing the number of antennas on the receiver side can provide adequate array and diversity gains. Self-interference between waves and non-orthogonality are all limitations imposed by GFDM. Therefore, researchers designed using Z-transform and optimal

exploitation of the transmitter matrix structure to address this problem and used linear receivers that provide solutions for GFDM systems.

K. Anish et.al ([Anish Pon Yamini et al., 2021](#)) improving efficiency, effective spectrum utilization, power consumption, and reducing latency through the use of D2D device-to-device communication for 5G wireless communication systems are discussed. Researchers have proposed using Low Density Parity Check Codes (LDPC) with GFDM technology to enhance D2D communication. The simulation results have demonstrated the potential of this new scheme to improve access time and high throughput on D2D communications over transport channels. Thus, the proposed algorithm holds an optimal solution for the implementation of smart cities in the advanced communication network systems applied by next-generation ones. XIAOTONG et.al ([Zhang et al., 2020](#)) his approach is the merger of promising waveforms and filters designed for 5G, which is composed of waveforms from GFDM systems and NOMA non-orthogonal multiple access systems for the power field-a new approach for 5G networks. The main motivation of this merger is to perform the evaluation of NOMA-GFDM systems and to measure the BER against the resulting outcomes. Simulation results indicate that the combination technology provides significant advantages in performance, such as reduced PAPR and out-of-band power radiation (OOBP), against other multiple-access technologies. Fereshteh et.al ([Yazdani et al., 2021](#)) this is a complete study and analysis of the effects of CFO, TO, PN and non-linearity of power amplifier distortion on the performance of GFDM systems. GFDM performance exists in the presence of these parameters in comparison with OFDM. Simulation results show that GFDM is more sensitive to nonlinear distortion and CFO but PN and TO are more robust concerning GFDM systems.

YEONGJUN et.al ([Kim et al., 2022](#)) focus on comprehensively addressing the challenges of high throughput in IoT networks for future generations, in addition to low latency. To achieve this goal, GFDM-based grant-free asynchronous transceiver (GF-AMA) systems are developed and evaluated. Two types of GFDM-based receivers are proposed: A Minimum Mean Square Error (MMSE) receiver and a Successive Interference Cancellation (SIC) receiver. The latter scheme provides higher throughput with only a limited increase in the computational load of the user equipment. The research emphasizes the advantages of GFDM over OFDM in terms of lower OOBE. GFDM is proposed as a solution to achieve low latency and high throughput in asynchronous multiple access scenarios.

MARIANA et.al ([Mello and Mendes, 2022](#)) The paper presents a method to improve the spectral efficiency of a GFDM system. It achieves this by utilizing the fastest Nyquist principle in both the time and frequency domains. The paper explores various detectors on the receiver

side to reduce complexity. It uses several detectors to reconstruct the transmitted data. It analyzes the data in terms of its error rate performance under different channel models and implementation complexities. This includes a spherical decoder and code-by-code sequence estimation. The paper also discusses the application of polar coding to FTN-GFDM systems and its impact on performance in different channel models. The simulation results showed that the proposed algorithm provides better performance in terms of spectral efficiency with lower computational cost. Polar encoding provides even better performance in ICI and ISI as well as gains in reliability.

S. Selvin et.al ([Selvin Pradeep Kumar, Agees Kumar and Jemila Rose, 2023](#)), a technique is proposed to reduce PAPR in GFDM systems. The technique proposed by the researchers is based on Selective Level Mapping (SLM) using the Chaos Biogeography-Based Optimization algorithm (CBBO). Simulation results showed that the proposed technique addresses the high PAPR in the waveforms of GFDM systems and reduces the PAPR better compared to traditional SLM methods such as OFDM-SLM, GFDM. It is particularly suitable for QAM and QPSK applications due to its excellent performance in minimizing PAPR and low computational complexity.

R. JeganlalIn et.al ([Jeganlal et al., 2023](#)) This paper proposed a system, with a high data rate can be achieved by using larger signal constellations, higher-order modulation schemes, and advanced receiver structures. The performance of the GFDM system in 5G cellular networks can be analyzed using various iterative receiver structures. Moreover, channel losses are improved due to AWGN for different SNRs, where GFDM yields better results compared to OFDM. The MMSE receiver structure provides a better performance analysis compared to other receiver structures such as MF and ZF, which are used for reducing interference.

Vincent et.al ([Vincent, Hamid and Permana, 2023](#)) The researchers in the study focused on improving the performance of channel estimation for GFDM systems. They achieved this by using adaptive thresholding to estimate the length of the channel impulse response (CIR) through discrete Fourier transform (DFT), and then providing improved performance via LS. The paper contributed significantly to the treatment of CIR for GFDM systems.

Yung-Yi et.al ([Wang, Chen and Hsu, 2023](#)) The paper discusses the use of the effective maximum likelihood (ML) algorithm for estimating the carrier frequency shift (CFO) in GFDM systems. The algorithm repeats the sub-codes of the received signal and virtual carriers, resulting in improved estimation accuracy compared to traditional algorithms. This also leads to an increase in spectral efficiency while keeping computational complexity low, as

demonstrated by simulation results. The effectiveness of the algorithm in addressing frequency synchronization challenges in the high-frequency communications range is also highlighted.

- The research papers explain various techniques to improve the characteristics and refinement of GFDM technology to address various challenges such as reducing complexity and spectral efficiency, improving the performance of wireless communication systems and nonlinear distortions, and addressing problems such as PAPR, BLER, OOBE, and BER.
- The research covered a wide range of communication systems and was not limited to those mentioned previously. To address these issues, several waveform filters have been proposed for the material layer, including Non-Orthogonal Multiple Access (NOMA), GFDM, Universal Filtered Multi-Carrier (UFMC), and Filter Bank Multi-Carrier (FBMC) in 5G wireless networks (Öztürk, Basar and Çirpan, 2017).

Table 3. Comparison of various techniques used with GFDM.

Author(s)	Content Summary
Byungju Lim et.al 2018 (Mohanraj and Dananjayan, 2020)	Optimal receiver filter design proposed for GFDM in multi-user uplink systems. Mitigates timing and carrier frequency offset effects. Improves GFDM performance without reducing spectral efficiency.
Mohanraj et.al 2019 (Ameer H. Ali and Hreshee, 2023)	GFDM system with variable window LDGT improves BER performance, reduces interference and compares with other technologies in GFDM receivers.
Khalil et.al 2019 (Li, Niu and Dong, 2019)	Analyzes high-bit-rate CO-MB-GFDM signal performance over a long-range nonlinear SSMF link using digital signal processing techniques for long-range fibres communication systems.
Wheberth et.al 2019 (Rajappa et al., 2020)	Designs a low-complexity GFDM receiver with MMSE equalization. Evaluate performance in frequency-selective fading channels. Analyzes complexity and SER.
ZHENYU NA, et.al 2019 (Wang and Fortier, 2022)	Proposes GFDM-based cooperative relay system with WPC scheme, outperforms OFDM, improves quality of experience and extends battery life.
Siva et.al 2020 (Hema, Ananthi and Diana, 2023)	GFDM offers benefits over OFDM. Proposed low-complexity GFDM receiver using USRP. Reduces computational complexity with no effect on BER performance.
AMIRHOSSEIN et.al 2020 (Mizutani et al., 2018)	Compares GFDM and OFDM links in weak RF conditions, discussing their ability to handle attenuation and PA effects and exploring SI cancellation techniques.

6. CONCLUSION

This paper provides an overview of GFDM and its importance in 5G systems. GFDM is considered a solution to most of the problems faced by OFDM technology, such as effectively using the spectrum, meeting the requirements for higher data rates, and reducing OOB

emissions. The challenges associated with GFDM were discussed, including proposed techniques to reduce interference resulting from its non-orthogonal nature. This interference can occur between ISI symbols and between ICI carriers. The paper also discusses estimation techniques, different pulse shaping filters, MIMO-GFDM channel performance analysis, and the integration of different channel types. Furthermore, the paper compares the performance of GFDM with that of OFDM, taking into account the bit error rate (BER) measure.

This research paper is a valuable resource for engineers, researchers, and anyone involved in operating or designing 5G systems. It provides ideas about analyzing and developing the performance of GFDM in the field of ongoing research and development of 5G communication systems.

7. REFERENCES

Aissaoui, K., Mhatli, S. and Attia, R. (2019) 'High data rate multiband GFDM over long-haul standard single mode fiber communication', 2019 15th International Wireless Communications and Mobile Computing Conference, IWCMC 2019, pp. 1764–1766. Available at: <https://doi.org/10.1109/IWCMC.2019.8766716>.

Al-Dulaimi, O.M.K. et al. (2023) 'Strategy for Non-Orthogonal Multiple Access and Performance in 5G and 6G Networks', *Sensors*, 23(3). Available at: <https://doi.org/10.3390/s23031705>.

Ali, A.H. and Hreshee, S.S. (2022) 'Comparing the GFDM Transceiver System to', 2022 2nd International Conference on Advances in Engineering Science and Technology (AEST), 2022, pp. 539–542. Available at: <https://doi.org/10.1109/AEST55805.2022.10412948>.

Ali, Ameer H and Hreshee, S.S. (2023) 'Developed PC-GFDM based on interleaver', *Int. J. Nonlinear Anal. Appl.*, 14(January), pp. 2008–6822. Available at: <http://dx.doi.org/10.22075/ijnaa.2023.29374.4139>.

Ali, Ameer H. and Hreshee, S.S. (2023) 'Gfdm Transceiver Based on Ann Channel Estimation', *Kufa Journal of Engineering*, 14(1), pp. 33–49. Available at: <https://doi.org/10.30572/2018/kje/140103>.

Ameen, M.J.M. and Hreshee, S.S. (2022) 'Securing Physical Layer of 5G Wireless Network System over GFDM Using Linear Precoding Algorithm for Massive MIMO and Hyperchaotic QRDecomposition', *International Journal of Intelligent Engineering and Systems*, 15(5), pp. 579–591. Available at: <https://doi.org/10.22266/ijies2022.1031.50>.

Amertet, S. (2022) 'F-OFDM in a novel form for analyzing 5G networks', *Journal of Information Technology and Computing*, 3(1), pp. 1–16. Available at: <https://doi.org/10.48185/jitc.v3i1.489>.

Andrews, J.G. et al. (2014) 'What will 5G be?', *IEEE Journal on Selected Areas in Communications*, 32(6), pp. 1065–1082. Available at: <https://doi.org/10.1109/JSAC.2014.2328098>.

Anish Pon Yamini, K. et al. (2021) 'GFDM-Based Device to Device Systems in 5G Cellular Networks', *Lecture Notes on Data Engineering and Communications Technologies*, 63, pp. 653–660. Available at: https://doi.org/10.1007/978-981-16-0081-4_65.

Carrillo, D. et al. (2018) 'Bit error probability for MMSE receiver in GFDM systems', *IEEE Communications Letters*, 22(5), pp. 942–945. Available at: <https://doi.org/10.1109/LCOMM.2018.2808475>.

Chuang, Y., Ueng, F.B. and Shen, Y.S. (2021) 'A Cyclic Prefix Free Multiple Input Multiple Output Generalized Frequency Division Multiplexing System Design', *Wireless Personal Communications*, 117(2), pp. 311–336. Available at: <https://doi.org/10.1007/s11277-020-07870-6>.

Dias, W.D., Mendes, L.L. and Rodrigues, J.J.P.C. (2019) 'Low Complexity GFDM Receiver for Frequency-Selective Channels', *IEEE Communications Letters*, 23(7), pp. 1166–1169. Available at: <https://doi.org/10.1109/LCOMM.2019.2914445>.

Ehsanfar, S. et al. (2019) 'Pilot- and CP-Aided Channel Estimation in MIMO Non-Orthogonal Multi-Carriers', *IEEE Transactions on Wireless Communications*, 18(1), pp. 650–664. Available at: <https://doi.org/10.1109/TWC.2018.2883940>.

Ehsanfar, S., Chafii, M. and Fettweis, G. (2019) 'Time-Variant Pilot- and CP-Aided Channel Estimation for GFDM', *IEEE International Conference on Communications*, 2019-May, pp. 1–6. Available at: <https://doi.org/10.1109/ICC.2019.8761411>.

ERSİN ÖZTÜRK and ERTUGRUL BASAR (2017) 'Generalized Frequency Division Multiplexing', *Special Section on Index Modulation Techniques for*, 5(21), pp. 24727–24746.

Fettweis, G., Krondorf, M. and Bittner, S. (2009) 'GFDM - Generalized frequency division multiplexing', *IEEE Vehicular Technology Conference*, pp. 1–4. Available at: <https://doi.org/10.1109/VETECS.2009.5073571>.

Gaspar, I. et al. (2015) 'GFDM - A Framework for Virtual PHY Services in 5G Networks', (July). Available at: <http://arxiv.org/abs/1507.04608>.

Gupta, M. and Gamad, R.S. (2023) 'Performance Analysis of Generalized Frequency Division Multiplexing in Various Pulse-Shaping Filter with Raised Cosine and Root Raised Cosine Filter', *Wireless Personal Communications*, 130(4), pp. 2839–2851. Available at: <https://doi.org/10.1007/s11277-023-10405-4>.

Hema, R., Ananthi, A. and Diana, D.C. (2023) 'Coded GFDM with decision feedback equaliser for enhanced performance in underwater wireless optical communication', *Opto-Electronics Review*, 32. Available at: <https://doi.org/10.24425/opelre.2024.148697>.

Islam, S.M.R. et al. (2019) 'Nonorthogonal Multiple Access (NOMA): How It Meets 5G and Beyond', *Wiley 5G Ref*, pp. 1–28. Available at: <https://doi.org/10.1002/9781119471509.w5gref032>.

Jayati, A.E. et al. (2018) 'Characteristic of HPA Nonlinear Distortion Effects in MIMO-GFDM Systems', 9th International Conference on Information and Communication Technology Convergence: ICT Convergence Powered by Smart Intelligence, ICTC 2018, pp. 379–384. Available at: <https://doi.org/10.1109/ICTC.2018.8539527>.

Jeganlal, R. et al. (2023) 'Performance Analysis of GFDM System in 5G Cellular Networks', *International Journal of Circuits, Systems and Signal Processing*, 17, pp. 39–43. Available at: <https://doi.org/10.46300/9106.2023.17.4>.

Jeong, J. et al. (2018) 'Eigendecomposition-based GFDM for interference-free data transmission and pilot insertion for channel estimation', *IEEE Transactions on Wireless Communications*, 17(10), pp. 6931–6943. Available at: <https://doi.org/10.1109/TWC.2018.2864995>.

Kalsotra, S. et al. (2019) 'Impact of pulse shaping design on OOB emission and error probability of GFDM', *IEEE 5G World Forum, 5GWF 2019 - Conference Proceedings*, pp. 226–231. Available at: <https://doi.org/10.1109/5GWF.2019.8911699>.

Kassam, J. et al. (2020) 'Hybrid Multiuser Equalizer for mmWave Massive MIMO GFDM Systems', 2020 12th International Symposium on Communication Systems, Networks and Digital Signal Processing, CSNDSP 2020 [Preprint]. Available at: <https://doi.org/10.1109/CSNDSP49049.2020.9249481>.

- Kaviya, M. and Sumathi, D.S. (2020) 'Nonlinear Distortion Effects In Generalized Frequency Division Multiplexing', *International Journal of Emerging Science and Engineering*, 6(8), pp. 10–15. Available at: <https://doi.org/10.35940/ijese.h2463.036820>.
- Khan, M.Q. and Danish Nisar, M. (2021) 'Spatial Transmit Diversity for GFDM via Low Complexity Transceiver Design', *IEEE Vehicular Technology Conference*, 2021-April. Available at: <https://doi.org/10.1109/VTC2021-Spring51267.2021.9448721>.
- Kim, Y. et al. (2022) 'GFDM-Based Asynchronous Grant-Free Multiple-Access', *IEEE Access*, 10, pp. 31012–31030. Available at: <https://doi.org/10.1109/ACCESS.2022.3160017>.
- Kishore, V. et al. (2020) 'Implementation of Linearly Pulse Shaped Generalised Frequency Division Multiplexing for Visible Light Communication Systems', *IEEE Open Journal of the Communications Society*, 1(4), pp. 1614–1622. Available at: <https://doi.org/10.1109/OJCOMS.2020.3030118>.
- Kumar, P. et al. (2018) 'Ber analysis of gfdm system augmented with sc diversity combining scheme for diverse pulse shaping filters', *Proceeding of 2018 12th International Conference on Telecommunication Systems, Services, and Applications, TSSA 2018*, pp. 1–6. Available at: <https://doi.org/10.1109/TSSA.2018.8708808>.
- Kusumakar, D., Pancholi, D. and Tiwari, V. (2019) 'GFDM 5G Cellular Network using MIMO System', *International Journal of Computer Applications*, 178(21), pp. 1–3. Available at: <https://doi.org/10.5120/ijca2019918971>.
- Li, Y. et al. (2019) 'Fast-convolution multicarrier based frequency division multiple access', *Science China Information Sciences*, 62(8), pp. 1–17. Available at: <https://doi.org/10.1007/s11432-018-9808-5>.
- Li, Y., Niu, K. and Dong, C. (2019) 'Polar-Coded GFDM Systems', *IEEE Access*, 7, pp. 149299–149307. Available at: <https://doi.org/10.1109/ACCESS.2019.2947254>.
- Li, Z., Nimr, A. and Fettweis, G. (2019) 'Implementation and performance measurement of flexible radix-2 GFDM modem', *IEEE 5G World Forum, 5GWF 2019 - Conference Proceedings*, pp. 130–134. Available at: <https://doi.org/10.1109/5GWF.2019.8911718>.
- Lim, B. and Ko, Y.C. (2018) 'Optimal receiver filter for GFDM with timing and frequency offsets in uplink multiuser systems', *IEEE Wireless Communications and Networking Conference, WCNC*, 2018-April, pp. 1–6. Available at: <https://doi.org/10.1109/WCNC.2018.8377271>.

- Liu, J.T. and Ap, L. (no date) '5G Technology Fundamentals', (877).
- Maraş, M. et al. (2021) 'A novel gfdm waveform design based on cascaded wht-lwt transform for the beyond 5g wireless communications', *Sensors*, 21(5), pp. 1–20. Available at: <https://doi.org/10.3390/s21051831>.
- Matthé, M. et al. (2016) 'Precoded GFDM transceiver with low complexity time domain processing', *Eurasip Journal on Wireless Communications and Networking*, 2016(1), pp. 1–9. Available at: <https://doi.org/10.1186/s13638-016-0633-1>.
- Mello, M.B. and Mendes, L.L. (2022) 'Low-Complexity Detection Algorithms Applied to FTN-GFDM Systems', *IEEE Access*, 10(September), pp. 101683–101696. Available at: <https://doi.org/10.1109/ACCESS.2022.3208878>.
- Merah, H., Mesri, M. and Tahkoubit, K. (2018) 'Significant reduction of Bit Error Rate in 5G-GFDM system using concatenated turbo code with Low Density Parity Check Code in fading channels', *Journal of Electrical Systems*, 14(1), pp. 118–129.
- Michailow, N. et al. (2014) 'Generalized frequency division multiplexing for 5th generation cellular networks', *IEEE Transactions on Communications*, 62(9), pp. 3045–3061. Available at: <https://doi.org/10.1109/TCOMM.2014.2345566>.
- Mizutani, K. et al. (2018) 'Performance Evaluation of Universal Time-domain Windowed GFDM-based LTE Uplink', *International Symposium on Wireless Personal Multimedia Communications, WPMC, 2018-Novem(1)*, pp. 156–161. Available at: <https://doi.org/10.1109/WPMC.2018.8712894>.
- Mohammadian, A. and Tellambura, C. (2020) 'Cognitive GFDM full-duplex radios with RF impairments and ACI constraints', *IEEE Open Journal of the Communications Society*, 1(April), pp. 732–749. Available at: <https://doi.org/10.1109/OJCOMS.2020.2993611>.
- Mohanraj, S. and Dananjayan, P. (2019) 'Performance analysis of GFDM system using LDGT for varying window', *2019 IEEE International Conference on System, Computation, Automation and Networking, ICSCAN 2019*, pp. 1–4. Available at: <https://doi.org/10.1109/ICSCAN.2019.8878800>.
- Mohanraj, S. and Dananjayan, P. (2020) 'OMP based Iterative Channel Estimation Algorithm for Modified GFDM System', *2020 International Conference on System, Computation, Automation and Networking, ICSCAN 2020*, pp. 15–17. Available at: <https://doi.org/10.1109/ICSCAN49426.2020.9262383>.

Na, Z. et al. (2018) ‘Turbo receiver channel estimation for GFDM-based cognitive radio networks’, *IEEE Access*, 6, pp. 9926–9935. Available at: <https://doi.org/10.1109/ACCESS.2018.2803742>.

Na, Z. et al. (2019) ‘GFDM Based Wireless Powered Communication for Cooperative Relay System’, *IEEE Access*, 7, pp. 50971–50979. Available at: <https://doi.org/10.1109/ACCESS.2019.2911176>.

Nimr, A. et al. (2017) ‘A study on the physical layer performance of GFDM for High Throughput wireless communication’, 25th European Signal Processing Conference, EUSIPCO 2017, 2017-Janua, pp. 638–642. Available at: <https://doi.org/10.23919/EUSIPCO.2017.8081285>.

Nivetha, V. and Sudha, V. (2021) ‘BER Analysis of GFDM System under Different Pulse Shaping Filters’, 2021 International Conference on Wireless Communications, Signal Processing and Networking, WiSPNET 2021, pp. 53–56. Available at: <https://doi.org/10.1109/WiSPNET51692.2021.9419396>.

Öztürk, E., Basar, E. and Çirpan, H.A. (2017) ‘Spatial modulation GFDM: A low complexity MIMO-GFDM system for 5G wireless networks’, 2016 IEEE International Black Sea Conference on Communications and Networking, BlackSeaCom 2016 [Preprint]. Available at: <https://doi.org/10.1109/BlackSeaCom.2016.7901544>.

Öztürk, E., Basar, E. and Çirpan, H.A. (2019) ‘Multiple-input multiple-output generalized frequency division multiplexing with index modulation’, *Physical Communication*, 34, pp. 27–37. Available at: <https://doi.org/10.1016/j.phycom.2019.02.004>.

Park, J. et al. (2022) ‘Extreme ultra-reliable and low-latency communication’, *Nature Electronics*, 5(3), pp. 133–141. Available at: <https://doi.org/10.1038/s41928-022-00728-8>.

Permana, A.K. and Hamid, E.Y. (2018) ‘DFT-Based channel estimation for GFDM on multipath channels’, *Proceedings of 2018 10th International Conference on Information Technology and Electrical Engineering: Smart Technology for Better Society, ICITEE 2018*, (2), pp. 31–35. Available at: <https://doi.org/10.1109/ICITEED.2018.8534919>.

Rajappa, A.C.J. et al. (2020) ‘Golden Coded GFDM for 5G Communication’, *Wireless Personal Communications*, 115(3), pp. 2335–2348. Available at: <https://doi.org/10.1007/s11277-020-07684-6>.

Sameen, M. et al. (2017) ‘2016’, (April).

Selvin Pradeep Kumar, S., Agees Kumar, C. and Jemila Rose, R. (2023) 'An efficient SLM technique based on chaotic biogeography-based optimization algorithm for PAPR reduction in GFDM waveform', *Automatika*, 64(1), pp. 93–103. Available at: <https://doi.org/10.1080/00051144.2022.2106532>.

Shayanfar, H., Saeedi-Sourck, H. and Farhang, A. (2018) 'CFO and Channel Estimation Techniques for GFDM', 2018 IEEE MTT-S International Microwave Workshop Series on 5G Hardware and System Technologies, IMWS-5G 2018, pp. 1–3. Available at: <https://doi.org/10.1109/IMWS-5G.2018.8484326>.

Sim, Z.A. (2020) 'PAPR Reduction in Multicarrier Communication Systems Using Efficient Pulse Shaping Technique', (March).

Sim, Z.A. et al. (2020) 'Performance of gfdm systems using quadratic programming pulse shaping filter design', *IEEE Access*, 8(Cc), pp. 37134–37146. Available at: <https://doi.org/10.1109/ACCESS.2020.2975430>.

Tai, C., Su, B. and Jia, C. (2019) 'FREQUENCY-DOMAIN DECOUPLING FOR MIMO-GFDM SPATIAL MULTIPLEXING Department of Electrical Engineering , National Taiwan University , Taiwan Graduate Institute of Communication Engineering , National Taiwan University , Taiwan', pp. 4799–4803.

Tai, C.-L., Wang, T.-H. and Huang, Y.-H. (2020) 'An Overview of Generalized Frequency Division Multiplexing (GFDM)', pp. 1–14. Available at: <http://arxiv.org/abs/2008.08947>.

Tsai, F.-C., Ueng, F.-B. and Lin, D.-C. (2021) 'Low-Complexity Receiver for Massive MIMO-GFDM Communications', pp. 117–126. Available at: <https://doi.org/10.5121/csit.2021.112009>.

Vaezi, M., Ding, Z. and Vincent Poor, H. (2018) Multiple access techniques for 5G wireless networks and beyond, *Multiple Access Techniques for 5G Wireless Networks and Beyond*. Available at: <https://doi.org/10.1007/978-3-319-92090-0>.

Valluri, S.P., Vejandla, K. and Mani, V.V. (2020) 'Low complex implementation of GFDM system using USRP', *IET Communications*, 14(13), pp. 2060–2067. Available at: <https://doi.org/10.1049/iet-com.2019.1106>.

Vincent, V., Hamid, E.Y. and Permana, A.K. (2023) 'Adaptive threshold for discrete fourier transform-based channel estimation in generalized frequency division multiplexing system', *ETRI Journal*, (June), pp. 1–12. Available at: <https://doi.org/10.4218/etrij.2023-0003>.

Wang, Y. and Fortier, P. (2022) ‘Performance analysis of LDPC coded GFDM systems’, *IET Communications*, 16(14), pp. 1663–1673. Available at: <https://doi.org/10.1049/cmu2.12415>.

Wang, Y.Y., Chen, B.R. and Hsu, C.H. (2023) ‘Efficient Maximum Likelihood Algorithm for Estimating Carrier Frequency Offset of Generalized Frequency Division Multiplexing Systems’, *Mathematics*, 11(15). Available at: <https://doi.org/10.3390/math11153426>.

Yadav, S.P. (2022) ‘Pulse Based GFDM Modulation Technique for Future Generation Communication Systems’, *European Journal of Electrical Engineering and Computer Science*, 6(6), pp. 1–8. Available at: <https://doi.org/10.24018/ejece.2022.6.6.468>.

Yazdani, F. et al. (2021) ‘Characterization of GFDM Signal with Timing Offset, CFO, Non-Linearity, and PN’, *Research Square*, pp. 0–14. Available at: <https://doi.org/10.21203/rs.3.rs-747120/v1>.

Zhang, X. et al. (2020) ‘On the Performance of GFDM Assisted NOMA Schemes’, *IEEE Access*, 8, pp. 88961–88968. Available at: <https://doi.org/10.1109/ACCESS.2020.2994083>.

Zhang, Z. et al. (2017) ‘Universal filtered multi-carrier transmission with adaptive active interference cancellation’, *IEEE Transactions on Communications*, 65(6), pp. 2554–2567. Available at: <https://doi.org/10.1109/TCOMM.2017.2681668>.

Zhong, J. et al. (2018) ‘Iterative Frequency Domain Equalization for MIMO-GFDM Systems’, *IEEE Access*, 6, pp. 19386–19395. Available at: <https://doi.org/10.1109/ACCESS.2018.2823002>.